



Features and Benefits

The SLT3 Tester provides instant identification of most common voice and data cabling problems including shorts, opens, reversals, and miswires.

The master and remote units separate for end-to-end testing of installed cabling. Shorts, opens, reversals, or miswires are easily detected within seconds—the continuously sequencing LED display immediately alerts you to problems in the cabling system. Both pieces simply snap and lock together when not in use, making it easy to carry and store. When the units are interlocked, the battery is disabled, thus prolonging battery life.

Designed to fit into a tool box or pocket, the SLT3 Tester has a convenient "ring" feature for attaching to a belt or frame. A durable nylon carry case may be purchased as an optional accessory. Frame adapters are available for testing from the punch down block to the wall plate in one simple operation.

Approvals UL 1863

Material Thermoplastic UL94V-0

Mechanical Characteristics

- Power Requirements: 9V Alkaline Battery (included)
- Max Distance: 10,000 ft.
- Interface: USOC, 568A and 568B
- Mating: 4W, 6W, 8W and 8W-keyed plugs
- Contact Material: 50 pinches gold over 100 pinches nickel

Reference Information

- Parts List for SLT3 Single Line Tester
 - SLT3 Single Line Tester (1 Remote and 1 Master unit)
 - Instructions

Optional Items

- Carry Case
- Accessory Kit includes:
 - Carry Case
 - 2 8W Line Cords
 - 2 Frame Adapters (KATT 568A and KATT 568B)
 - 1 RJ11-RJ45 Adapter

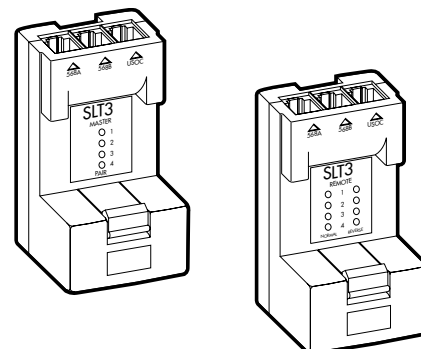

SLT3 Single Line Tester

Set Dimensions:
146mm x 58mm x 38mm
(5.75"H x 2.3"W x 1.5"D)
Shipping Weight: 224g (8 oz.)

Master Dimensions:
109mm x 58mm x 38mm
(4.3"H x 2.3"W x 1.5"D)
Shipping Weight: 140g (5 oz.)

Remote Dimensions:
109mm x 58mm x 38mm
(4.3"H x 2.3"W x 1.5"D)
Shipping Weight: 84g (3 oz.)

Demonstration of mated SLT3 Tester with Carry Case

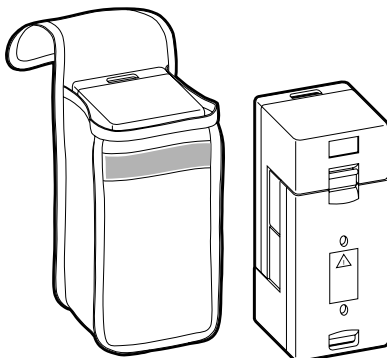

ORDERING INFORMATION

Order No.	Description
33-100	SLT3 Single Line Tester
33-100-P	SLT3 Carry Case
33.B0010	SLT3 Accessory Kit—includes Carry Case, two 8-wire line cords, two frame adapters (KATT 568A and KATT 568B) and one RJ11-RJ45 Adapter. SLT3 Not Included.
33.B0020	SLT3 Tester with Carry Case

MOLEX PREMISE NETWORKS

Molex Premise Networks
Corporate Headquarters
New Hampshire, USA
Tel: 1 603 324 0200
www.molexpn.com

European Headquarters
Hampshire, England
Tel: 44 (0) 1489 527111
www.molexpn.co.uk

Pac Rim Headquarters
Victoria, Australia
Tel: 61 3 9971 7111
www.molexpn.com.au